

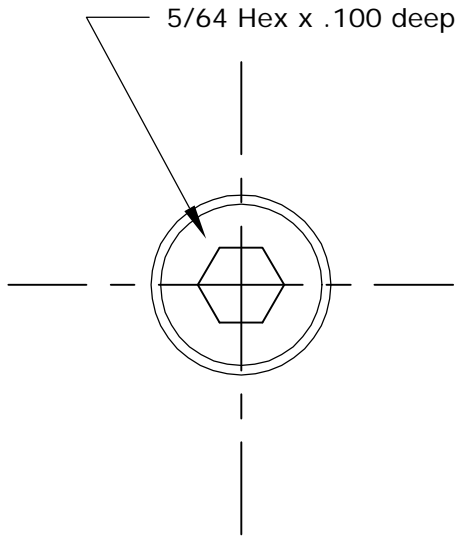

REVISIONS				
ZONE	REV	DESCRIPTION	DATE	APPROVED

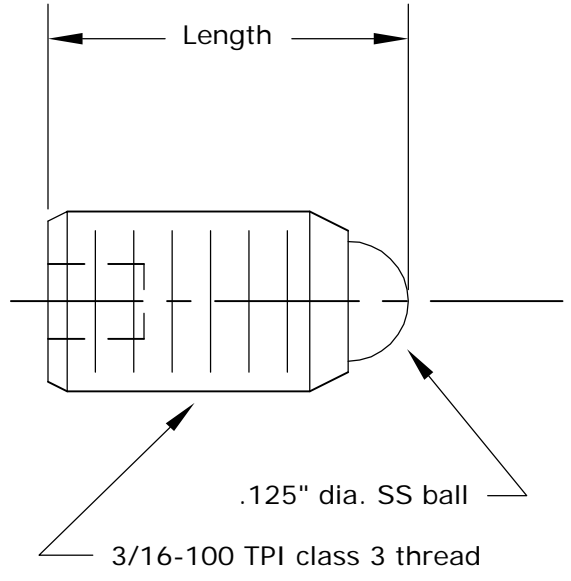

NAME	LENGTH
FA1-S100-1	1/4
FA1-S100-2	3/8
FA1-S100-3	1/2
FA1-S100-4	5/8
FA1-S100-5	3/4
FA1-S100-6	7/8
FA1-S100-7	1.0
FA1-S100-8	1 1/8
FA1-S100-9	1 1/4
FA1-S100-10	1 3/8
FA1-S100-11	1 1/2
FA1-S100-12	1 5/8
FA1-S100-13	1 3/4
FA1-S100-14	1 7/8
FA1-S100-15	2.0
FA1-S100-16	2 1/8
FA1-S100-17	2 1/4
FA1-S100-18	2 3/8
FA1-S100-19	2 1/2
FA1-S100-20	2 5/8
FA1-S100-21	2 3/4
FA1-S100-22	2 7/8
FA1-S100-23	3.0
FA1-S100-24	3 1/8
FA1-S100-25	3 1/4
FA1-S100-26	3 3/8
FA1-S100-27	3 1/2
FA1-S100-28	3 5/8
FA1-S100-29	3 3/4
FA1-S100-30	3 7/8
FA1-S100-31	4.0

.125" dia. SS ball
3/16-100 TPI class 3 thread



					APW Company						
					FINE ADJUSTMENT SCREWS					FA1-S100	
					SIZE	FSCM NO.		DWG NO. FA1-S100		REV	
					SCALE Dim.		SHEET				

