

REVISIONS				
ZONE	REV	DESCRIPTION	DATE	APPROVED

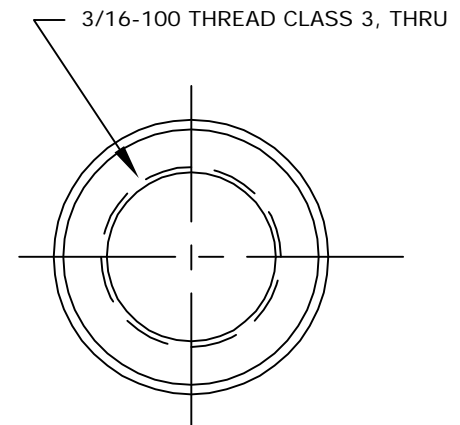
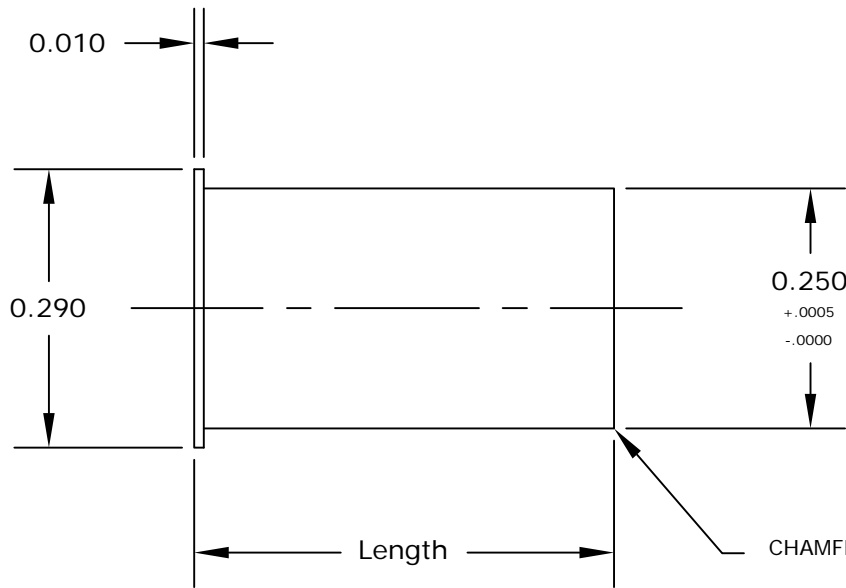

NAME	Length
FA1-B100-1	5/16
FA1-B100-2	7/16
FA1-B100-3	5/8

		APW Company		
		FINE ADJUSTMENTS BUSHING FA1-B100		
SIZE	FSCM NO.	DWG NO.	FA1-B100	REV
SCALE Dim.		SHEET		